



### Main Features

- Made from AISI 316 (inside& lid) AISI304 (outside) stainless steel.
- Teflon or similar plastic food grade materials are used.
- Maximum capacity of the bowl is 910l. Product processing capacity is min. 150L., max. 400L.
- Dimensions in mm (Length x Width x Height): 1881x3650x3035 (-/+35).
- Working ambient temperature should be between 12°C and 35°C.
- Operating voltage 350-415V, the maximum frequency is 50-60 Hz, respectively.
- Vacuum pump is used.
- Maximum vacuum (negative) pressure in the bowl; -0.5 bar, the maximum positive pressure, 0.5 bar, respectively.
- Maximum allowable pressure in the jacket is 2 bar and maximum temperature is 152°C.
- Indirect and / or direct steam could be applied into the product.
- Steam pressure to double jacket should be 2 bar.
- Steam pressure to nozzles for direct steam injection should be 6 bar.
- Maximum operating temperature for the product is 95°C.
- There are 4 steam nozzles for direct steam.
- Steam consumption is 600 kg / h
- Cooling water can be applied from the wall.
- Water pressure should be between not less than 3 bar.
- Air pressure supplied to the machine is 6-8 bar.
- The shaft of knives motor has double seal with water cooling system.
- The speed of the mixer motor varies from 300 to 3000rpm while could be regulated with inverter control on the touch screen upon recipe.
- There are two knives made of hardened steel material (Made in Germany)
- There are three scrapers.
- Purified air is pumped into the bowl during product discharge.



- On the touch screen, may be sited the target temperature, the amount of process water which will be let it the bowl through flowmeter, vacuum application and the speed of the knives motor. 10 different recipes may be saved upon production.
- The product will be discharged with pneumatic valve.
- Lid opening closing is done hydraulically.
- Lid locking is done pneumatically.
- Steam, water and vacuum suction hoses are made up of Teflon which are dressed with spiral stainless-steel bellows.
- Flowmeter is used which could be controlled on the touch screen (HMI) by PLC system.
- The machine provided with mobile steam station which consists of; a steam filter with carbon cartridge paired with condensate trap, a steam separator paired with condensate trap, stainless steel filter paired with condensate trap, pressure gauges & pressure regulation valves. Stainless steel filter filtrates steam up to 1-5µm, made from 316L stainless steel, have operating temperature between - 20°C / +210°C, cleanable and reusable.

## Optional Features & Equipment

- Automatic lifter with 2 baskets to add raw materials.
- Parts which have contact with product made of stainless steel AISI316 grade.
- Regulation of negative pressure of vacuum pump.
- Maximum operating temperature for the product of 125°C.
- Funnel on the lid for feeding by vacuum of small volume of ingredients during cooking process without of interruption of cooking process and open/close of the lid.
- Floor mounted funnel(s) for feeding by vacuum of big volume of ingredients during cooking process without of interruption of cooking process and open/close of the lid.
- Mass flow meter for automatic feeding of melted fat or oil to the bowl according the recipe from touch screen (HMI).
- Flow speed control valve for melted fat or oil into the bowl.
- Buffer tank for preliminary accumulation of ready products for further continuous feeding it to filling machine.
- Centrifugal CIP pump for cleaning of buffer tank and piping.
- Lobe pump for transferring ready products from the mixer to the buffer tank and from the buffer tank to the filling machine.



- Twin-screw pumps for transferring ready products from the mixer to the buffer tank and from the buffer tank to the filling machine. (A twin-screw pump is required for high viscosity products or pump it to higher points)
- Feta-cut (Micro-cut mechanical homogenizer) for micron grinding / homogenizing of the product.
- Sight glass with lamp and wiper.

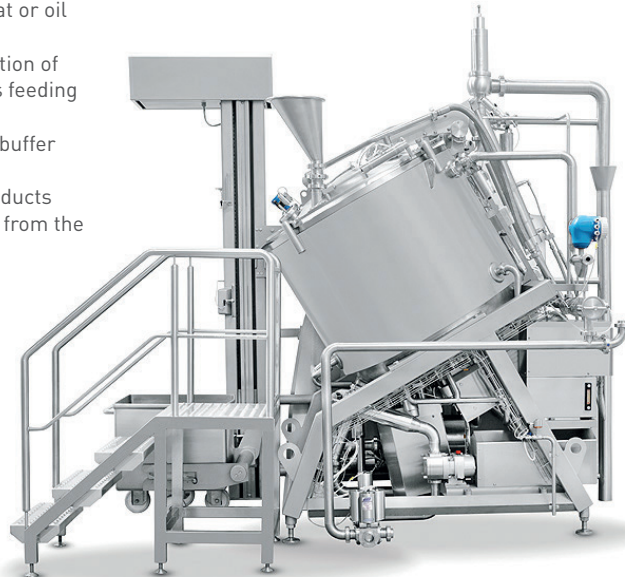

## Technical Data

### Machine Data

Bowl capacity **910 (l) approx.**  
 Batch quantity (product-dependent)  
**150-400 (l) min.- max.**  
 Max. vacuum in bowl **-0.9 bar**  
 Max. over pressure in the bowl **1.5 bar**  
 Max. operating temperature in the bowl **95 °C**  
**Optional: 125 °C**  
 Max. operating pressure in the double jacket **2.0 bar**  
 Max. operating temperature in the double jacket **152 °C**  
 Min./max. compressed air **6-8 bar**  
 Steam **600 kg/h**

### Energy Requirement

Total electric consumption **43,2 / 82 kW / A**  
 Power **350/415 – 50/60 V / Hz**

### Spare Parts

- Lid seal	- 1 piece
- Set of scrappers	- 1 piece
- Union wrench DN-40	- 1 piece
- Union wrench DN-50	- 1 piece
- Union wrench DN-65	- 1 piece
- Knives replacement wrench	- 1 piece
- PT100 Temperature sensor	- 1 piece
- Cable for PT-100 sensor	- 1 piece
- M18 Inductive sensor	- 1 piece
- Single contact relay	- 2 piece
- Double contact relay	- 2 piece
- Pneumatic sensor	- 1 piece

## Dimensions

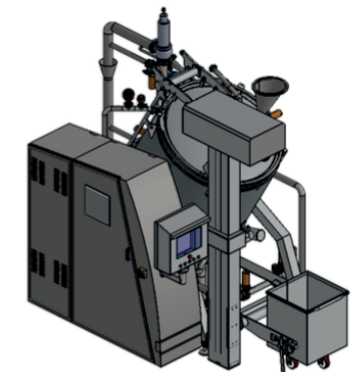
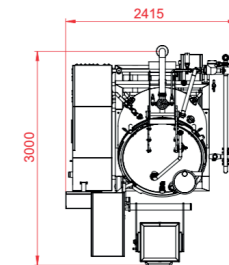
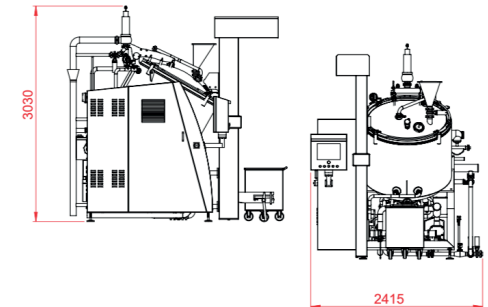

### ROKK Processing Ltd

Wolvey Lodge Business Centre, Cloudsley Bush Lane, Wolvey, Leicestershire, LE10 3HB, England  
 T. +44 (0)1455 220 179 F. +44 (0)1455 221 314 E. sales@machineryworld.com